

# AIRMATE-USB

ANALOG PRODUCTION | ON-AIR CONSOLE



**W**e designed the Airmate-USB to fulfil the requirements for a high grade low cost radio production mixer. Built around well proven low noise circuitry, this console is the reliable workhorse for the self-op production D.J. that needs an internal Telephone Hybrid (2x) and 2x USB connection to the PC (e.g. for streaming to the web)

A heavy duty 19" rack mounted RF shielded chassis houses 8 vertical triple input modules giving flexibility rarely found in a mixer of this type.

Six input channels with high quality balanced microphone inputs on XLR and two stereo line level inputs on Cinch (RCA) connectors. And... every line level line B input can be converted into a phono (gramophone) channel by simply fitting an optional stereo R.I.A.A. equalized phono pre-amp. On top of this we have added 4 Mic inserts for processing equipment.

## MIC, LINE, USB AND TELEPHONE IN-OUTS

This new Airmate-USB 8 channel model has 6 balanced mic inputs (+48 phantom is standard) with inserts for signal proc-essors, 12 stereo line inputs, 2x USB and 2x Telephone Hybrids.

Channel 5 and 6 have Mic/Line and USB interface to transfer audio from and to your PC. Channel 7 and 8 have, apart from the stereo line input, also RJ-11 connectors to interface with a POT line and a telephone appliance. High quality built in Hybrids with R and C balance and direct Talk back in the Hybrid channels makes a conversation with listeners very easy. The front panel ON switch is wired in series with the built in mechanical faderstart enabling selection of start either by fader or hard start via the ON switch. Faderstart generates in the Mic mode a Mic-on signalling to switch on ON-Air lights. There is a 3 band Equalizer on channel 1-6. The stereo Aux send can be set pre or post fader. All mic inputs have low cut jumpers. A clean feed send is available for external Hybrids.

## DESIGNED FOR RADIO

The Airmate-USB has the usual master controls such as stereo master faders, stereo Aux send and return, monitor master with "follow phones" and a phones output with a split control function. There is a balance control to continuously adjust the volume between main output and stereo Cue signal. In addition, there is a special Radio On-air/production section featuring; Self-op switching to automatically cut control room level when the D.J. mic is active; a Clean feed output to also drive an external Telephone Hybrid for talk shows and interviews, if you need more Hybrid channels than the 2 built in ones; a special announcer output that normally follows main output but can be switched so that the main output, or any cue signal that is selected, can be heard when in the "follow phones" mode.

A large Talkback switch activates the built-in electret talkback microphone for easy communication with the Clean-feed output, Aux output and/or Announcer output.



## NOW IS THE TIME TO INSTALL YOUR OWN ON-AIR | PRODUCTION ROOM | WEBRADIO

The Airmate-USB is designed to be the focal point for local radio production work in the studio or at home. It's comprehensive, yet understandable features make it the ideal companion for rapid on-the-spot radio programmes.

Small, reliable and 19" rack mounting ideal for production rooms. It can also double as an On-Air mixer or implemented in your own Internet Radio station. If your budget is tight, it never becomes obsolete as it can revert to production use, if, at a later date you fit in a larger On-Air mixer.



## SUMMARY

We hope this brief overview has given you a good insight into the potential of this new "Airmate-USB" on-air console.

If you require further information please do not hesitate to contact one of our offices or your local dealer who will be pleased to assist you.

Look at our website for distributor details.

## SPECIFICATIONS

### INPUTS

Mic inputs: balanced 2kOhm, XLR.  
Phantom: +48 volt.  
Noise: -122 dB (A-weighted).  
Sensitivity: -70dB min, 0dB max.  
Insert: Jack unbal. send 600 Ohm, -10dBV.  
Return: unbalanced 10kOhm -10dBV.  
Line inputs: unbal., 10kOhm, Cinch.  
Gain: range of 40dB.  
Phono inputs: unbal. 47kOhm, 5 mV.  
USB: 2x Stereo in and 2x stereo Program out.  
2 Track return: -10 dBV at 10kOhm.  
Aux returns: -10 dBV at 10kOhm stereo

### USB

Fully compliant with USB 2.0 playback and record mode. 2x Stereo in and main stereo left right signal on both USB connectors  
HID Functions: Volume/Mute

### TELEPHONE HYBRIDS

RJ-11 connectors for phone line/dialler  
Mix Minus rejection @1kHz -30dB.

### OUTPUTS

Left/Right: +4 dBu bal. XLR.  
Monitor/Aux : +4dBu unbal. on Cinch.  
Cleanfeed/Announcer: +4dBu, Jacks.  
Tape outp: -10dBV, unbal. Cinch.  
Headphone: 16-600 Ohm, Jack.  
Announcer: 16-600 Ohm, Jack.  
USB out: Main program stereo signal

### EQUALIZER

High: + / -12 dB at 12kHz shelving.  
Mid: + / -12dB at 1 kHz bell curve.  
Low: + / -12dB at 60 Hz bell curve.

### OVERALL

Frequency response: 10 - 60.000Hz.  
Distortion: < 0.009% max at 1 kHz.  
Start switch: reed relay.  
Ledbars: 21 segment.  
Power consumption: 30VA

## DIMENSIONS

Left-Right 19" rack mount (482mm width)  
Front-Back: 356mm (8HE).  
Height: 95mm.

Space below front panel: 20mm for table top.  
Weight: 11 kg.

For Drop through mounting cut a hole of 450 x 330 mm (console height is 95mm)

## HEADOFFICE

D&R Electronica Weesp b.v.  
Rijnkade 15B  
1382 GS WEESP  
The Netherlands  
Phone: ++31 (294) 418 014  
Fax: ++31 (294) 416 987  
Website : www.d-r.nl  
E-mail: info@d-r.nl



### TRIPLE INPUT MODULE

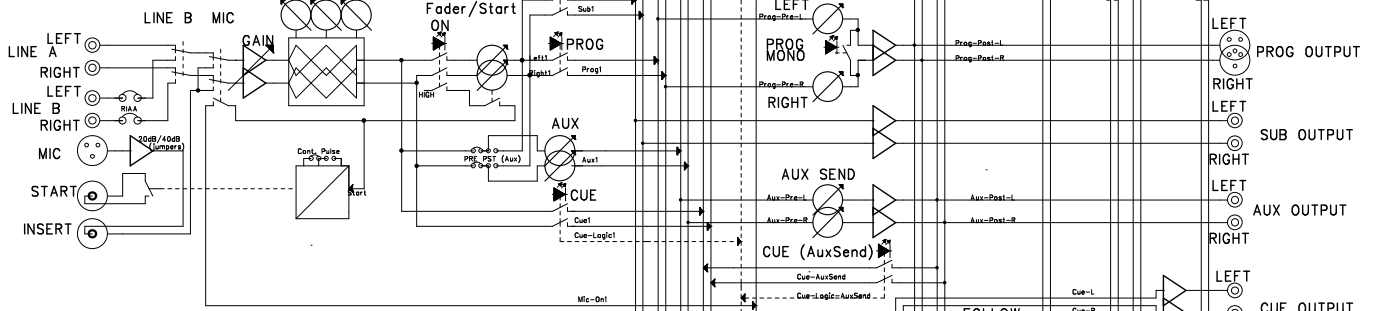

### USB-LINE MODULE

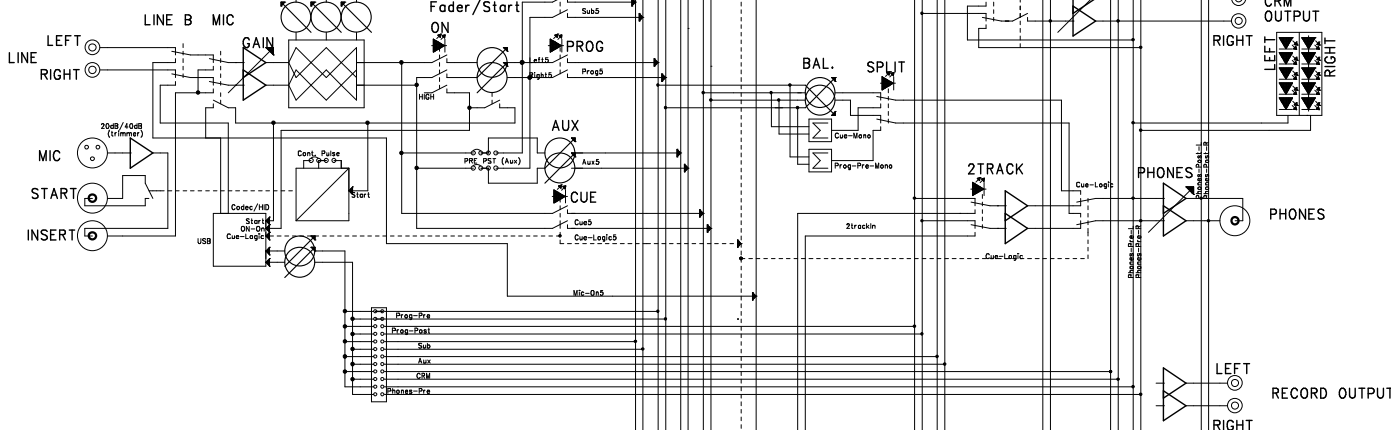

### TELCO-LINE MODULE

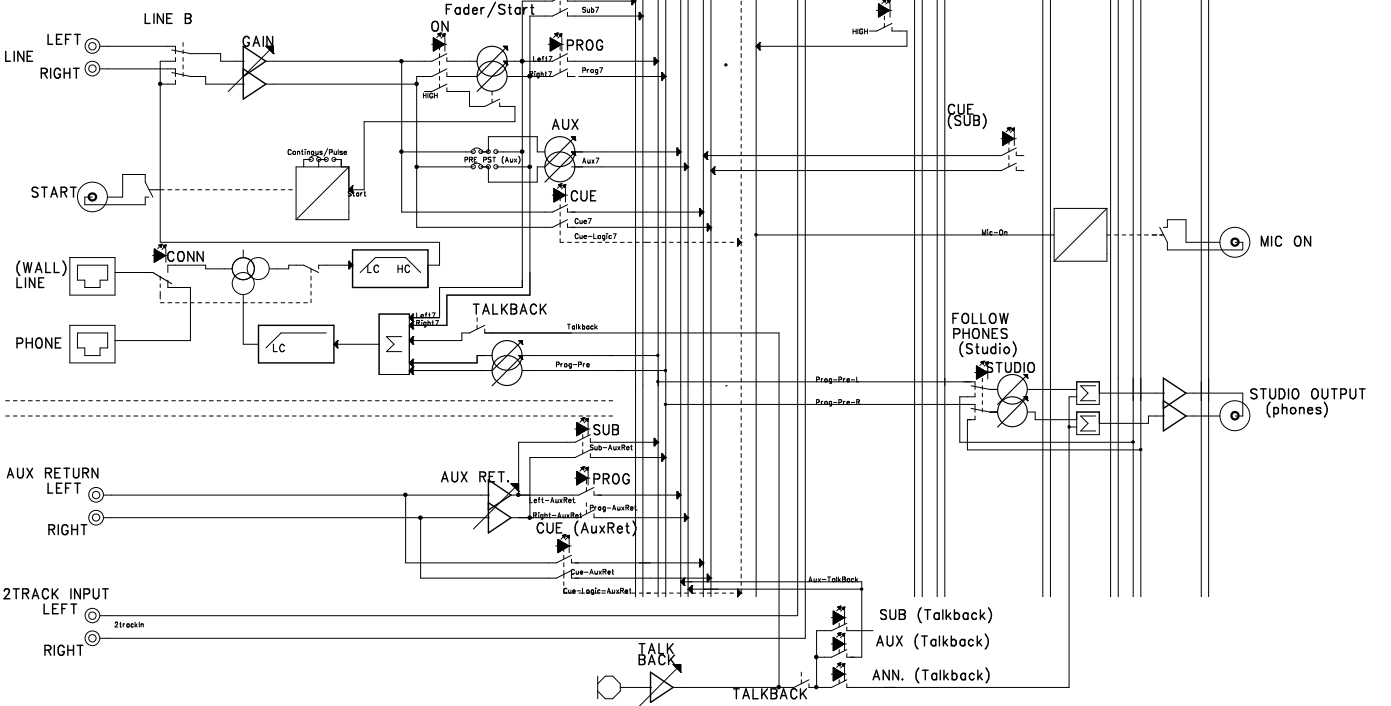

AIRMATE-USB SIGNAL FLOW